

Classpad Help Series sponsored by Casio Education Australia		www.casioed.net.au	
676	Vectors Closest Approach 1	Author	Charlie Watson
		Date	31 January 2010
		CPM OS	03.04.4000

Start in eActivity and tap **File, New**.

This eActivity contains a Main strip which can easily be re-used to solve closest approach problem using the dot product approach.

Example: A body A is at $2\mathbf{i} + 5\mathbf{j}$ and moving with velocity $3\mathbf{i} - \mathbf{j}$.

A second body B is at $\mathbf{i} + \mathbf{j}$ and moving with velocity $2\mathbf{i} + \mathbf{j}$.

Determine the time when A and B are closest, their minimum distance apart and the position vectors of A and B at this instant.

Tap **Insert, Strip, Main** and then **Resize**.

Enter the position and velocity vectors as shown, storing in **Ra**, **Va**, etc.

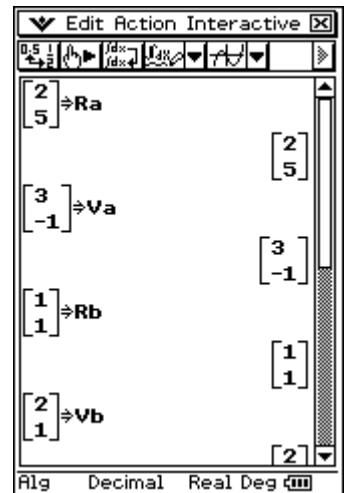

Next, create relative position and velocity vectors for A relative to B and store in **R** and **V**.

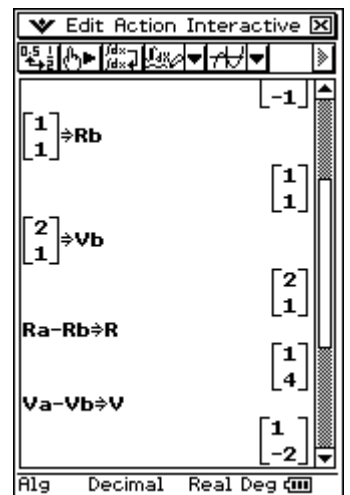

Closest approach will occur at the time when the dot product of the relative velocity vector **V** and the relative position vector **tV+R** is zero.

Enter the dot product and then solve the resulting expression equal to zero.

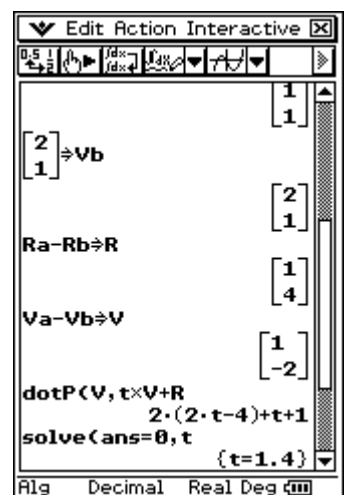

Store the resulting time into the variable **t1** for future use.

The distance apart of A and B is the magnitude of their relative positions given by $t\mathbf{V}+\mathbf{R}$ at the time of closest approach.

Finally, the positions of A and B at the time of closest approach are calculated.

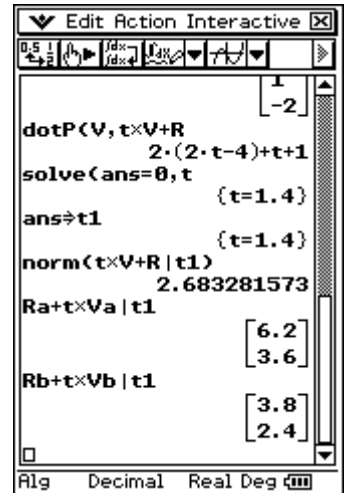

To use the strip for another problem, simply modify the initial position and velocity vectors, position the cursor on the VERY TOP LINE* and tap **EXE**.

The display is completely updated and you can see the basic calculations in finding the closest approach of A and B.

In the example shown with only **Ra** and **Va** modified as shown, note that A and B actually collide since their distance apart at time **t1** is 0.

** Note that this is important so that all stored variables are correctly updated.*

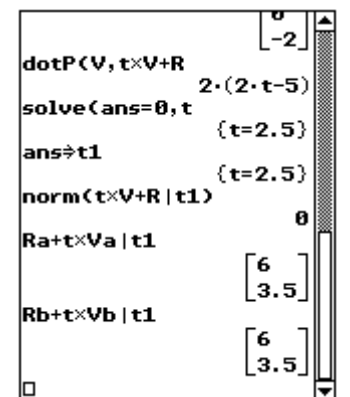
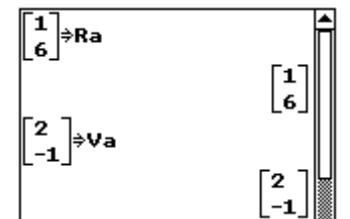

Close the strip, enter a suitable title for it and save the eActivity.

